

EWAQ130-150DAYN(P-B)

- 01 Evaporator
- 02 Condensor
- 03 Compressor
- 04 Expansion valve + sight glass
- 05 Discharge stopvalve (Optional)
- 06 Suction stopvalve (Optional)
- 07 Liquid stopvalve (Optional)
- 08 Chilled water IN (Victaulic coupling)
- 09 Chilled water OUT (Victaulic coupling)
- 10 Water drain evaporator
- 11 Air purge
- 12 Leaving water temperature sensor
- 13 Entering water temperature sensor
- 14 Ambient temperature sensor
- 15 Drier + charge valve
- 16 Power supply intake
- 17 Switchbox
- 18 Digital display controller (Inside switchbox)
- 19 Field wiring intake
- 20 Main isolator switch

- 21 Transport beam
- 22 Flowswitch
- 23 Fan
- 24 Safety valve
- 25 High pressure sensor
- 26 Low pressure sensor
- 27 High pressure switch
- 28 Oil sight glass
- 29 Pump (Optional)
- 30 Buffertank (Optional)
- 31 Expansion vessel (Optional)
- 32 Waterfilter
- 33 Water stopvalve (Optional)
- 34 Frame
- 35 Buffertank drain valve (Optional)
- 36 Regulating valve (Optional)
- 37 Water safety valve (Optional)
- 38 Pressure gauge (Optional)

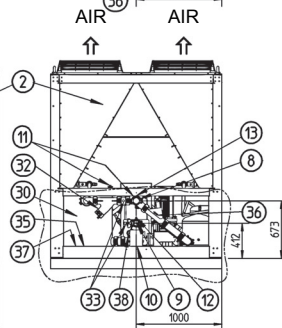
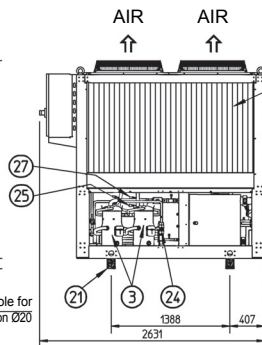
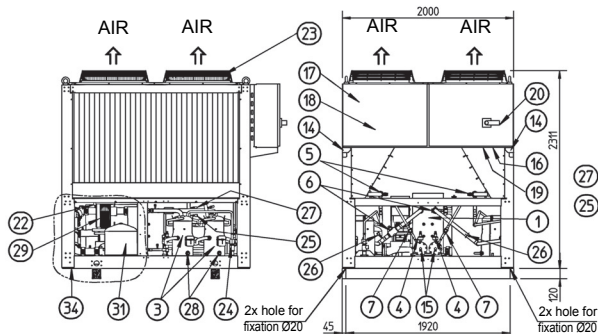
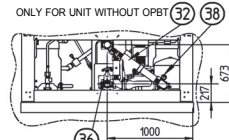
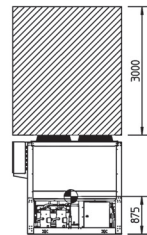
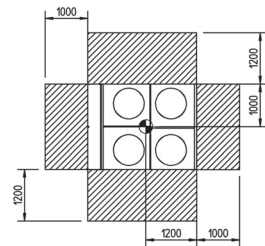
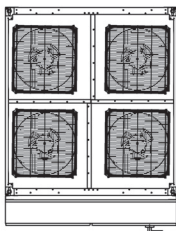

Legend

Required space around the unit for service and air intake

Center of gravity

