

FLXS50-60B

Floor level installation

The mark (→) shows piping direction

Required space
(for performance and maintenance)

→ Air flow (indoor)

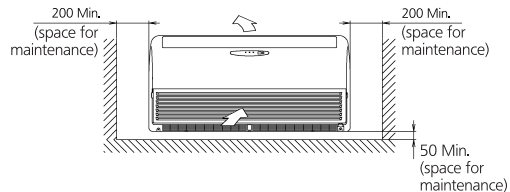
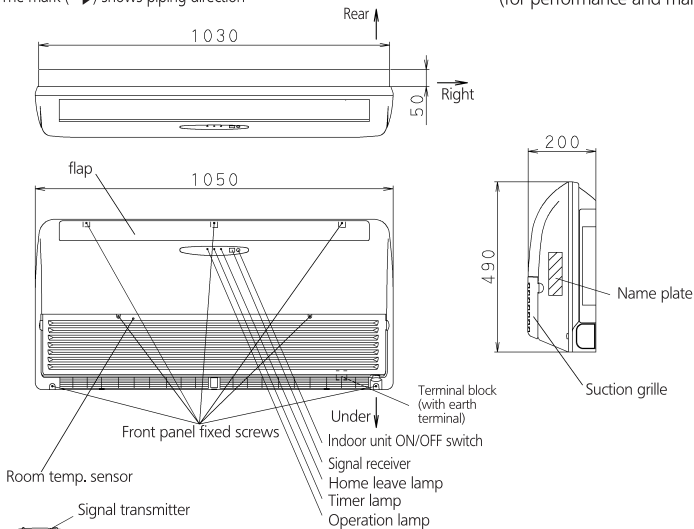

- Liquid pipe (ϕ 6.4 CuT)
- Gas pipe (ϕ 12.7 CuT)
- Drain hose (I.D. ϕ 14, O.D. ϕ 18)

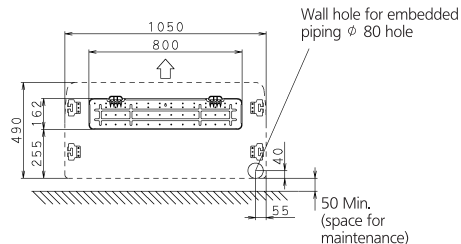
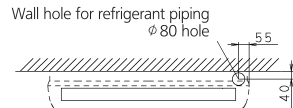

Standard locations of wall holes

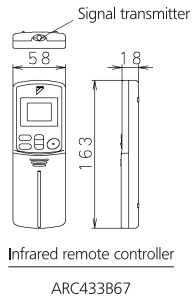

Blade angle

