

# 3MXS40K

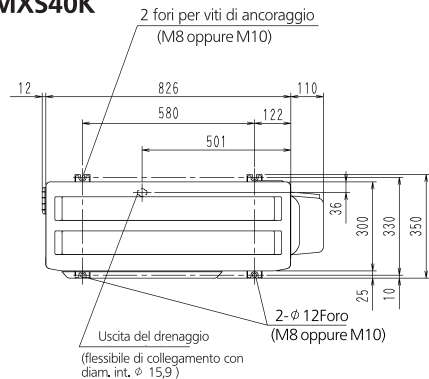

Spazio minimo per passaggio aria

Altezza della parete sul lato uscita aria = meno di 1200

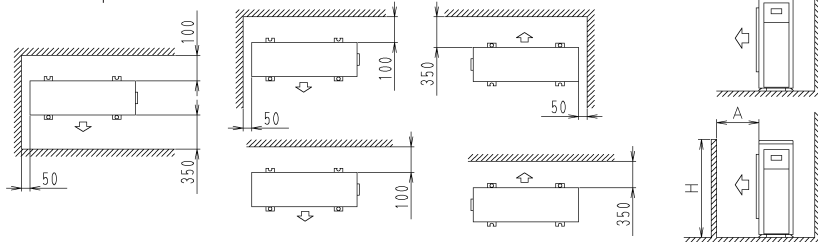

	Dimensioni A
H $\leq$ 1200	350
H > 1200	600

Spazio necessario per l'installazione sul lato mandata (mm)

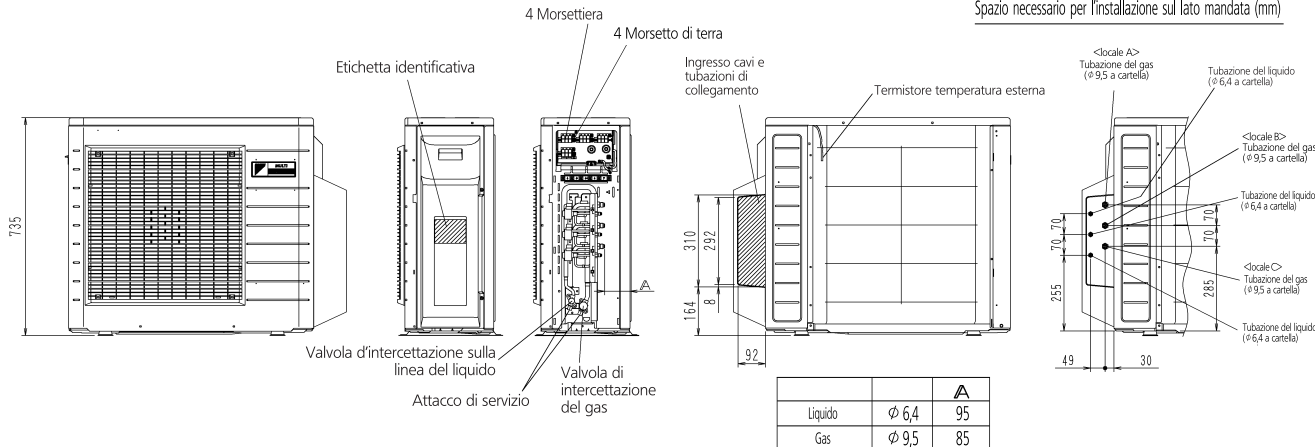

	$\phi$	A
Liquido	$\phi$ 6,4	95
Gas	$\phi$ 9,5	85