

3MXS68G

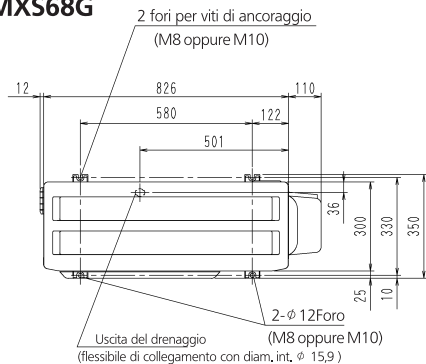

Spazio minimo per passaggio aria

Altezza della parete sul lato uscita aria = meno di 1200

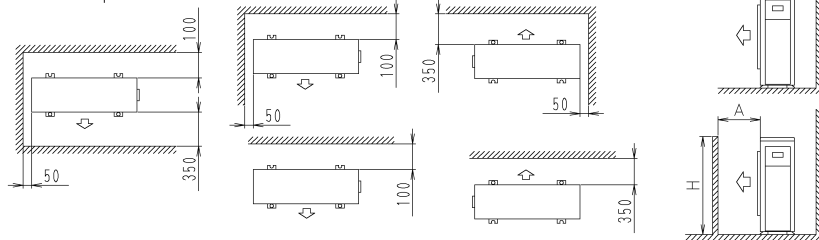

	Dimensioni A
H \leq 1200	350
H > 1200	600

Spazio necessario per l'installazione sul lato mandata (mm)

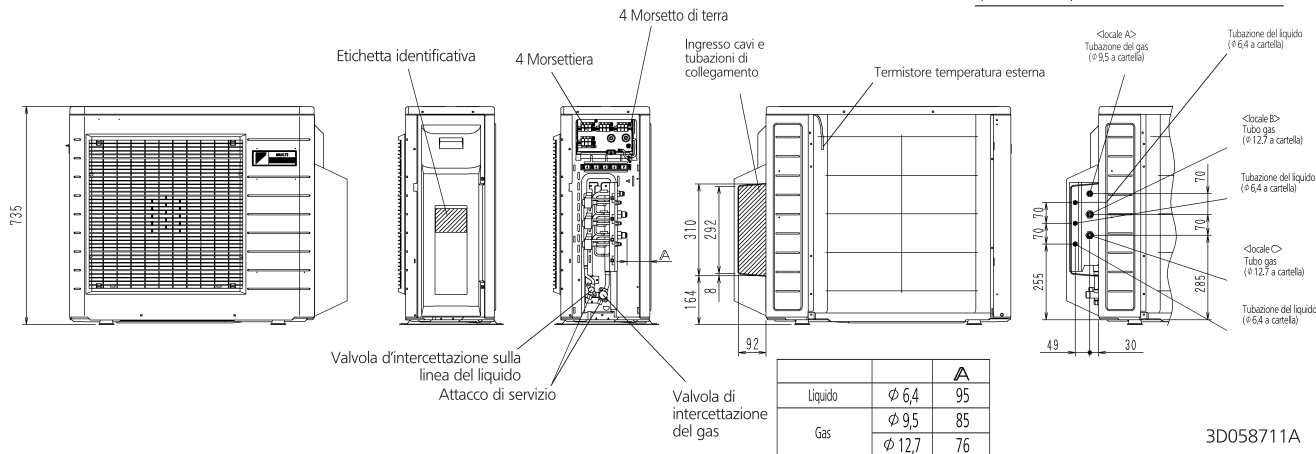

3D058711A