

FLXS25-35B

Installazione a pavimento

La freccia (→) indica la direzione dei tubi

Spazio necessario
(per funzionamento e manutenzione)

⇨ Portata aria (interna)

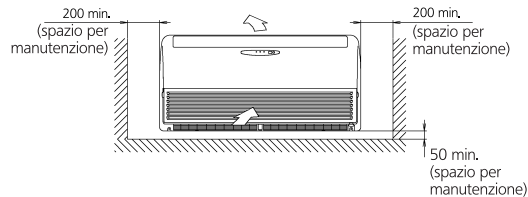
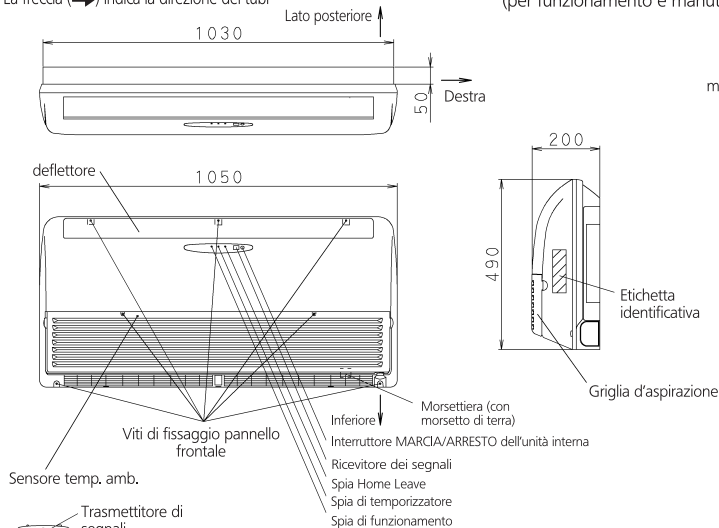

- Tubazione del liquido (ϕ 6,4 CuT)
- Tubazione gas (ϕ 9,5 CuT)
- Tubo flessibile (DI ϕ 14, DE ϕ 18)

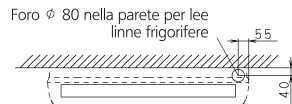

Angolo di mandata aria

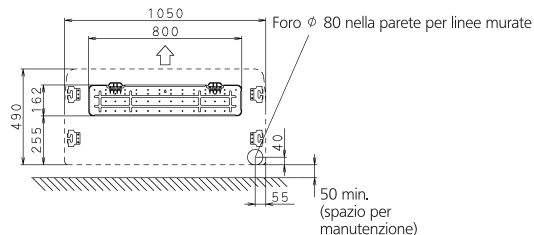
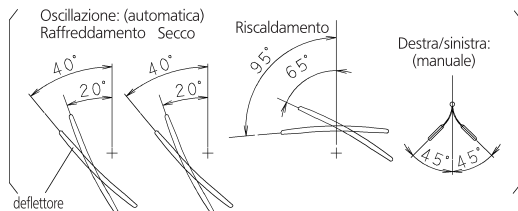

Posizioni standard degli fori sulla parete

Telecomando a raggi infrarossi

ARC433B67